



THE AGA KHAN UNIVERSITY

eCommons@AKU

LABRAD

Publications

9-2013

LABRAD : Vol 39, Issue 1 - September 2013

Aga Khan University Hospital, Karachi

Follow this and additional works at: <http://ecommons.aku.edu/labrad>



Part of the [Pathology Commons](#), and the [Radiology Commons](#)

Recommended Citation

Aga Khan University Hospital, Karachi, "LABRAD : Vol 39, Issue 1 - September 2013" (2013). *LABRAD*. Book 7.
<http://ecommons.aku.edu/labrad/7>

LABRAD

SEPTEMBER 2013

VOL. 39, ISSUE 1

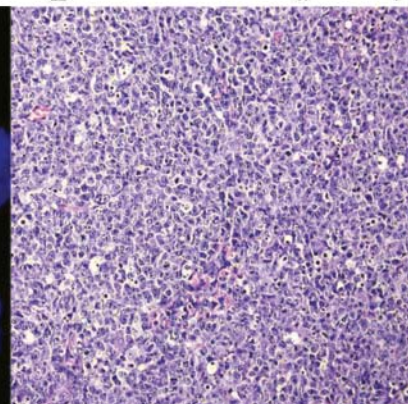
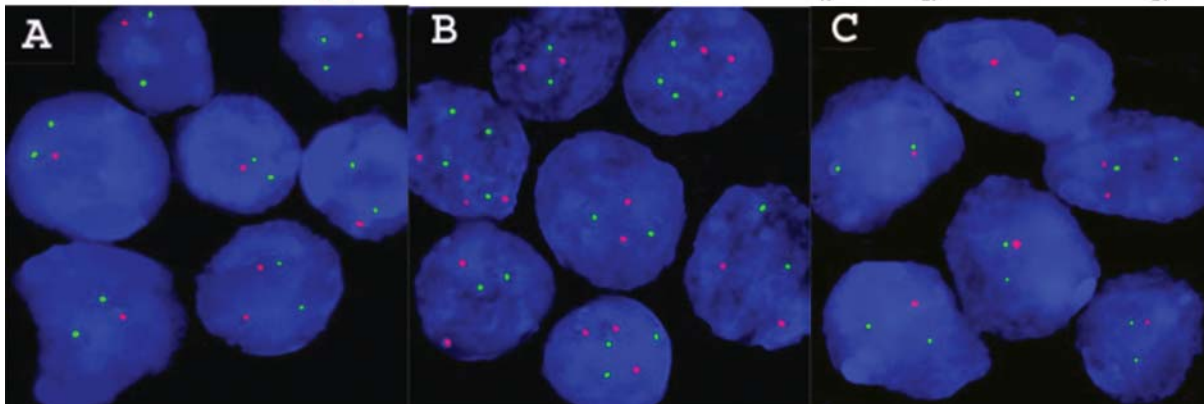
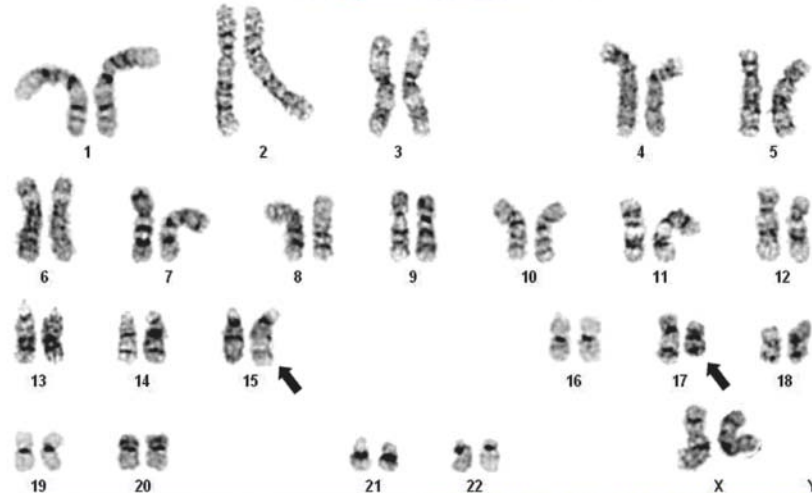
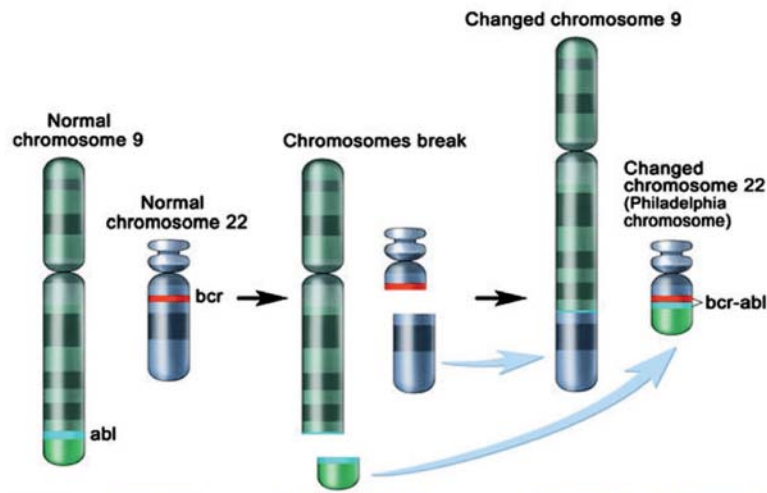
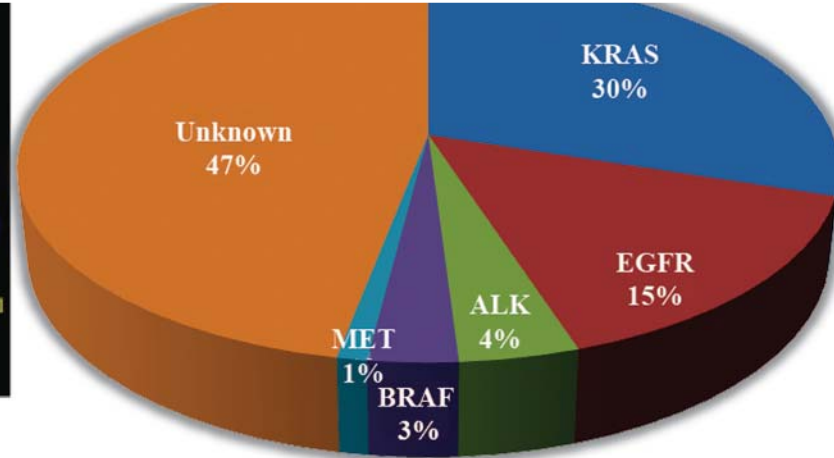
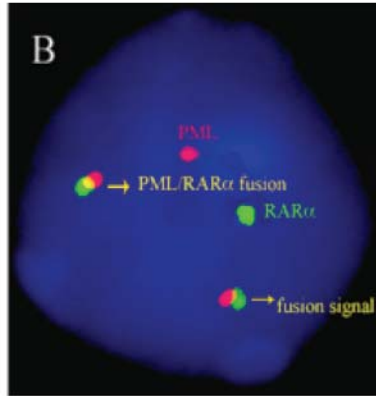
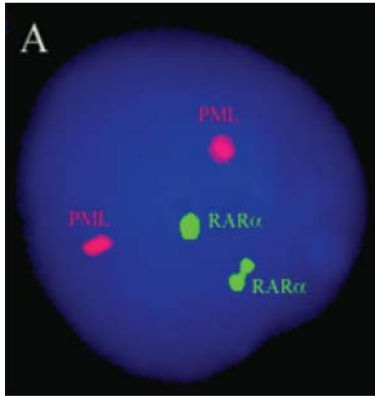

آغا خان یونیورسٹی ہسپتال، کراچی

The Aga Khan University Hospital, Karachi



LABRAD

A Publication of the Departments of Pathology and Microbiology and Radiology

September 2013
Volume 39, Issue 1

Editor
Dr. Aysha Habib

Assistant to Editor
Dr. Natasha Ali

Associate Editor
Dr. Bushra Moiz

Assistant to Associate Editor
Dr. Lena Jafri

Editorial Committee
Pathology and Microbiology
Dr Arsalan Ahmad
Dr Kauser Jabeen
Dr Zahra Hasan

Radiology
Dr Zishan Haider
Dr Naila Nadeem

Labrad Administration Office
Mr Kokab Mirza
Clinical Laboratories
Department of Pathology and Microbiology
Aga Khan University Hospital
Stadium Road, P. O. Box 3500
Karachi 74800, Pakistan

Tel: +92 21 3486 1551
Fax: +92 21 3493 4294, 3493 2095

hospitals.aku.edu/Karachi/pathologymicrobiology

Immunophenotyping by Flowcytometry 3

Chronic Lymphocytic Leukaemia: Diagnosis and Prognostic Factors 5

Tumour Markers 6

Role of Chemical Pathology in Screening and Diagnosis of Multiple Myeloma 9

1p/19q Deletion: Favourable Prognostic Marker for Oligodendroglioma 11

EGFR Mutation Screening Test for Lung Cancer Patients 13

Clinical Utility of BCR-ABL1 Kinase Domain Mutational Analysis 15

Molecular Cytogenetic Testing for Acute Myeloid Leukaemia 17

Diffuse Large B-Cell Lymphoma (DLBCL) Subgroups have Different Phenotype 19

Editorial

Haematopoietic and lymphoid neoplasms like lymphomas and leukemias are common occurrences both among adults and children. Fortunately, a significant number of these disorders are curable with modern chemotherapeutic regimen. First step is a precise laboratory diagnoses using modern diagnostic tools. Besides routine morphology diagnoses of these disorders has been revolutionized by immunological and genetic analyses. Quick transfer of modern tools from research lab to diagnostic lab and then to bedside is unprecedented and unmatched by developments in any other organ system. Indeed they are the bench mark from where a lot needs to be learnt by others.

The Aga Khan University Hospital Clinical Laboratory is equipped with required human and

physical resources. For example, a comprehensive 'Immunohistochemical', 'Flow Cytometric' and 'Cytogenetic' facility along with highly qualified and dedicated faculty to ensure precise diagnoses of these disorders from where begins the proper treatment of the patient follows.

In this issue we have mainly focused on the diagnostics of tumour screening and highlighted new tumour markers.

Dr Shahid Pervez,

Professor & Consultant Histopathology,
Department of Pathology & Microbiology,
Aga Khan University Hospital,

Immunophenotyping by Flowcytometry

Sidra Asad Ali
Haematology

Introduction

Over the past few years, the role of flowcytometry in haematology especially in malignant haematology has become inevitable. It has made a transition from being an experimental device of colossal magnitude confined to research laboratories, into a bench-top instrument of indispensable use in the diagnosis, classification and monitoring disease response.

Definition

The word 'cyto' means cell and 'metry' is measurement. So flowcytometry is measuring properties of cells in a flowing system. It evaluates optical and fluorescent characteristics of a cell or any other particle such as nuclei, microorganisms, chromosome preparations and latex beads.

When a fluorescent dye is conjugated to a monoclonal antibody, it can be used to identify a particular cell type based on the individual antigenic surface markers of the cell.

History

The original flowcytometer was the Coulter counter (Beckman Coulter M) invented by Wallace Coulter in the 1950s. It was in 1968, when the first fluorescence-based flow cytometry device (ICP 11) was developed by Wolfgang Göhde from the University of Münster, Germany and later commercialized by German developer and manufacturer Partec through Phywe AG in Göttingen. After a decade, in 1978, at the Conference of the American Engineering Foundation in Pensacola, Florida, the name flowcytometry was given to this methodology. Before that it was known as pulse cytophotometry.

Advancement in the field of immunophenotyping by flowcytometry with the availability of a wide variety of antibodies and fluorochromes (a fluorescent chemical compound that can re-emit light upon light excitation) has led to more accurate and precise identification of cells.

Principle

A beam of monochromatic light, usually from laser, intersects cells which are hydrodynamically-focused and are allowed to pass one by one through the point of interrogation. As soon as the interaction occurs, light is emitted in all directions and captured via detectors that direct the light to a series of filters and dichroic mirrors that isolate particular wavelength bands. These light signals are then detected by photomultiplier tubes and computerized for further analysis.

There are number of detectors that are placed at different points where the stream passes through the light beam. The one which is placed in line with the light beam is called forward side scatter and those placed perpendicular to light beam are known as side scatter. There are multiple fluorescence emission detectors as well which are placed at different positions.

Fluorochrome

It is a fluorescent dye is conjugated monoclonal antibodies, which then bind to specific proteins

(antigens) present on the surface, cytoplasm or nucleus of the cell. When these fluorochoime labeled cells are passed through a light beam, the fluorescent molecules absorbs light and caused the electrons to get into higher energy state. This excited electron quickly decays into a ground state or resting state and emit excess energy at a higher wave length. This transition of energy by different fluorochoimes allow multiple characteristics of the cells to be measured including cell size, cytoplasmic content, complexity, DNA or RNA properties, variety of membrane and intracellular proteins.

Propidium iodide, phycoerythrin, and fluorescein are the dyes which are commonly used. Tandem dyes with internal fluorescence resonance energy transfer can create even longer wavelengths and more colors.

Specimen

Flowcytometry is used for immunophenotyping of a variety of specimens, including whole blood, bone marrow aspirate, serous cavity fluids, cerebrospinal fluid, urine, fine needle aspiration and biopsies of lymph node and from other lymphoid tissues.

Table:1 Applications of Flowcytometry:

Field	Clinical application	Common characteristic measured
Hematology	Leukemia and lymphoma phenotyping	Leukocyte surface antigens
	Identification of prognostically important subgroups	TdT, MPO
	Hematopoietic progenitor cell enumeration	CD34
	Diagnosis of systemic mastocytosis	CD25, CD69
	Reticulocyte enumeration	RNA
	Hereditary Spherocytosis	Eosin-5'-maleimide-labeled intact red blood cells
	Autoimmune and alloimmune disorders	
	Anti-platelet antibodies	IgG, IgM
	Anti-neutrophil antibodies	IgG
	Immune complexes	Complement, IgG
Immunology	Feto-maternal hemorrhage quantification	Hemoglobin F, rhesus D
	Histocompatibility cross-matching	IgG, IgM
	Transplantation rejection	CD3, circulating OKT3
	HLA-B27 detection	HLA-B27
Oncology	Immunodeficiency studies	CD4, CD8
	DNA content and S phase of tumours	DNA
Blood banking	Measurement of proliferation markers	Ki-67, PCNA
	Immuno-hematology	Erythrocyte surface antigens
	Assessment of leukocyte contamination of blood products	Forward and side scatter, leukocyte surface antigens
Genetic disorders	PNH	CD55, CD59
	Leukocyte adhesion deficiency	CD11/CD18 complex

Ref: Flow Cytometry: Principles and Clinical Applications in Hematology. Clinical Chemistry. August 2000 vol. 46 no. 8 1221-1229

Immunophenotyping of Hematological Malignancies

The use of flowcytometry in haematological malignancies has a pertinent role. To begin with, only a restricted panel of monoclonal antibodies were used and it was largely focused on further characterization and determining the lineage (lymphoid versus myeloid origin of blast cells in acute leukemia) after the diagnosis of leukemia/lymphoma. Over the period of time, an extensive range of flourchomes have been developed and it is now used not only for diagnosis and classification but also for assessing prognosis, response of disease and for determining minimal residual disease with the help of individual immunophenotypic markers.

Limitations

Presence of particles in single-cell suspension only and properties of the fluorescent molecules used to stain the cells and photon statistics of fluorescence from the stained and unstained populations of cells are the few drawbacks of the methodology. Lack of standardization in and instrument set-up and assay is major limitation. Attention has been given and lot of efforts has been done to introduce standard protocols. Another limitation is subjectivity of the operator who gates the specific population, as the substantial amount of information generated which makes interpretation intricate. An important advancement in this regard is the development of gating tools,

automated multidimensional visualization as well as post-analysis data aggregation models.

Future Directions

There have been a lot of advancements which has improved the instrument, conjugated antibodies and the software. Image cytometry is the recent progress, which has combined modern multicolor flowcytometry with microscopy or transcriptional profiling.

Cytometry by mass cytometer, utilizes time-of-flight mass spectrometry to discriminate a set of more than 40 heavy metal ion-labeled antibodies without the shortcomings of fluorescence spillover or autofluorescence (Bendall et al., 2011, 2012). The Fluidigm Biomark system allows the quantification of mRNA levels using highly multiplexed real-time PCR using special microfluidic devices, thus allowing detection of up to more than 100 gene transcripts from a single cell.

Summary

Flowcytometer is a powerful tool for measuring multiple characteristics of a single cell. With the progression into smaller, user friendly and less expensive device and with also introduction of wide variety of antibodies, the use of flowcytometer has become ineluctable in the diagnosis and management of broad spectrum of diseases.

Chronic Lymphocytic Leukaemia: Diagnosis and Prognostic Factors

Dr Farheen Karim
Haematology

Chronic lymphocytic leukaemia (CLL) is a chronic B-cell lymphoproliferative disorder. It is more prevalent in the western population and is the most common type of leukaemia in the west. CLL is more commonly seen in men and in the elderly.

Diagnosis

Most of the patients with CLL are diagnosed incidentally based on lymphocytosis on a

complete blood count. However, some patients may present with lymphadenopathy, systemic symptoms such as fever, night sweats and weight loss or the symptoms of anemia or infection.

The diagnosis of CLL requires presence of $>5 \times 10^9/l$ circulating clonal B lymphocytes with characteristic morphology persisting for >3 months and a characteristic immunophenotype detected by flow cytometry.

Morphologically, lymphocytes in CLL are small in size with scanty cytoplasm. The nucleus shows clumped chromatin and the nucleolus is not visible. There is also presence of many smear or smudge cells on the peripheral film (as shown in Figure 1).

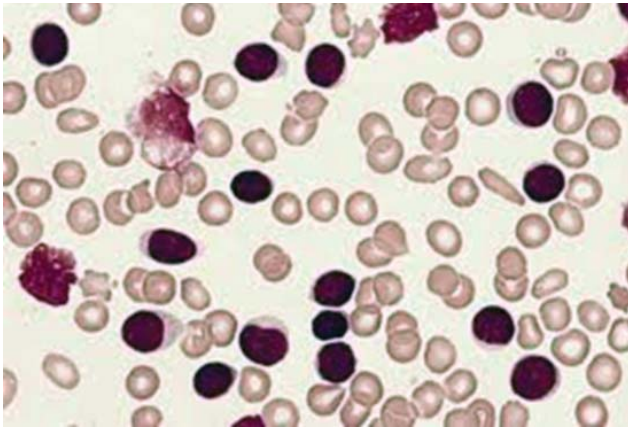

Figure 1: Peripheral film of a patient with CLL showing lymphocytosis and smear cells (AKUH Lab)

Immunophenotyping shows expression of CD19, CD20, CD23 and CD5. There is weak expression of surface membrane immunoglobulin with light chain restriction i.e. only a single immunoglobulin light chain (kappa or lambda) is expressed not both, confirming the clonal nature of these cells. Additionally, CLL cells are usually negative for cyclin D1 and CD10. FMC7, CD22, and CD79b are also commonly negative or weakly expressed.

Bone marrow examination is not essential for the diagnosis of CLL, but is mandatory

to define complete response after treatment. It is also indicated in determining the cause of cytopenias and assessing the pattern of involvement by the lymphoid cells (diffuse, nodular or interstitial).

Lymph node biopsy is only indicated when there is diagnostic uncertainty or clinical suspicion of lymphomatous transformation known as Richter's transformation.

Prognosis

The various factors that predict poor prognosis in CLL include the following:

- Advanced stage of disease (Binet B and C and Rai II and IV)
- Diffuse pattern of bone marrow infiltration
- No response to treatment
- Male sex
- Unmutated Immunoglobulin heavy chain (IgVH)
- High Zap-70 and CD 38 expression detected by flow cytometry
- High LDH and Beta-2 microglobulin levels
- P53 or deletion 17p detected by FISH has the worst prognosis. Detection of 11q23 deletions and trisomy 12 is also a bad prognostic marker. Presence of 13qDel as a sole abnormality confers a good prognosis.
- Rapid lymphocyte doubling time

Detection of these prognostic factors can help in predicting the course of illness in a patient.

Tumour Markers

Dr Syed Talha Naem
Chemical Pathology

Introduction

Current clinical practice has a growing impetus on early diagnosis, proper prognostication and screening for malignancy in asymptomatic groups. Tumour markers are assuming a growing role in all aspects of cancer care, starting from screening to follow-up after treatment. These markers are a structurally and functionally diverse group which includes amines, glycoproteins, hormones, enzymes, paraproteins and tumour associated antigens found in the blood, urine or tissues of patients with

certain types of cancer. They are typically produced by tumour cells, but in some cases they may be produced by the body in response to malignancy or to certain benign conditions. Tumour markers are not elevated in all cancer patients, particularly patients with early-stage cancer. They are measured qualitatively or quantitatively by chemical, immunological, or molecular biological methods. The characteristics of an ideal tumour marker are shown in Table 1.

Table 1: Characteristics of an Ideal Tumour Marker

Characteristics	Remarks
Highly specific	Detectable only in one tumour type
Highly sensitive	Non-detectable in physiological or benign disease states
Long lead-time	Sufficient time for alteration of natural course of disease
Levels correlate with tumour burden	Prognostic and predictive utility of the tumour marker
Short half-life	Frequent serial monitoring of the marker levels after 5-6 half lives
Simple and cheap test	Applicability as screening test
Easily obtainable specimens	Acceptability by target population

How are Tumour Markers Used?

Clinical uses can be broadly classified into 4 groups.

1. Screening and early detection: Screening refers to testing for cancer in people who have no symptoms of the disease. Early detection is finding cancer at an early stage, when it's less likely to have spread and is easier to treat. Tumour markers were first developed to screen for cancer – to look for cancer in people without symptoms – but very few markers have been shown to be helpful in this way. A perfect tumour marker would be one that could be used as a cancer screening blood test for all people. The tumour marker would only be elevated in people with cancer. At this time there are no tumour marker tests that work like this.

2. Diagnostic confirmation: By and large, tumour markers cannot be construed as primary modalities for the diagnosis of cancer, mainly because of the lack of sufficiently high specificity and sensitivity. Their main clinical utility is as a laboratory test to support the diagnosis or in follow-up of patients being treated for malignancy. Attempts to improve the sensitivity and/ or specificity of tumour markers have led to combination of tumour markers with other procedures (e.g., combination of Carbohydrate antigen (CA) 125 with ultrasonography for early detection of ovarian malignancy) or to refining the evaluation criteria for tumour markers (e.g., PSA density or PSA velocity or age-specific PSA cut off ranges for early detection of prostate cancer).

3. Prognosis and prediction of therapeutic response: Tumour marker levels, in certain situations, reflect tumour burden in the body and hence can be used in staging, prognostication or prediction of response to therapy. Markers usually

increase with progressive disease, decrease with remission and do not change significantly with stable disease. Tumour marker kinetics is generally more important than individual values.

4. Monitoring disease and recurrence: Monitoring disease is, perhaps, the most common clinical use of serum tumour markers. Rising trend in serum levels may detect recurrence of disease well before any clinical or radiological evidence of disease is apparent (“biochemical recurrence”).

When are Tumour Markers Measured?

It is imperative to remember that though an aggressive investigative approach may be warranted on the basis of raised tumour marker values, treatment cannot be initiated without undisputable documentation (often histological) of the disease. A single value or test is unreliable in itself. It is noteworthy that in most situations, elevations of markers in nonmalignant diseases are often transient, whereas elevations associated with cancer either remain constant or continuously rise. Ordering serial testing can help detect falsely elevated levels due to transient elevation.

Knowledge of the assay method is important in interpretation of either an abnormal value or a serial change in tumour marker values. Various methods of detection have their own specific cut off values and sensitivities. Thus, for any set of serial values to be meaningful, they have to come from the same assay methods and preferably from the same laboratory. In certain situations of so-called biochemical recurrences, it is always useful to go back to the laboratory to confirm this. In tumours with multiple raised markers measured prior to definitive therapy,

Table 2: Tumour markers tested in the section of Chemical Pathology, AKUH

Marker	Malignancy	Nonmalignant conditions
Alpha fetoprotein (AFP)	Hepatoma, Germ cell tumours	Viral hepatitis, liver injury, inflammatory bowel disease, pregnancy
β-hCG	Choriocarcinoma, Germ cell tumours	Testicular failure, marijuana smokers, pregnancy
Carcinoembryonic antigen (CEA)	Colorectal, stomach, pancreas	Smokers, inflammatory bowel disease, hepatitis, cirrhosis, pancreatitis, gastritis
CA 125	Ovarian	Peritoneal irritation, endometriosis, pelvic inflammatory disease, hepatitis, pregnancy
PSA	Prostate	Prostatitis, benign prostatic hyperplasia
CA 15-3	Breast	Liver cirrhosis, tuberculosis, sarcoidosis, benign breast disease, pelvic inflammatory disease, endometriosis, systemic lupus erythematosus, lactation and pregnancy
CA 19-9	Colorectal, stomach, pancreas	Biliary tract obstruction, cholangitis, inflammatory bowel disease, acute or chronic pancreatitis, liver cirrhosis, cystic fibrosis, thyroid disease
Calcitonin	Thyroid (Medullary carcinoma)	-
Beta-2-microglobulin	Myeloma, chronic lymphocytic leukemia (CLL), and some lymphomas (including Waldenstrom macroglobulinemia)	Kidney disease and hepatitis
Thyroglobulin	Thyroid (papillary, follicular)	-

the marker showing highest elevation should be used for follow-up.

Tumour marker kinetics should always be factored before repeating the tests. Too frequent estimation of the tumour marker may misrepresent the course of the disease due to distribution and elimination kinetics. As a general guideline, the time interval between serial determinations should be three months; but in case of an abnormal value, a repeat estimate can be ordered within two to four weeks irrespective of the initial reading.

The success of surgical removal of a tumour as determined by tumour marker concentrations is ideally ascertained after a period not less than 5-6

half-lives, to allow tumour marker levels to make a plateau or fall to normal. This period may be even longer in case of treatment with chemotherapy or radiotherapy, wherein the therapeutic effects themselves are manifested after a lag period.

Patient characteristics affect the tumour marker values to a significant degree. The anticipated fall in levels may not be evident in situations where the metabolism or excretion of the tumour marker is altered, like in patients with renal or liver disease, depending on whether the tumour marker is removed through glomerular filtration or metabolized by the liver. For example, serum CEA is often elevated in patients with liver diseases because the metabolism of CEA by the diseased liver is subnormal. False

tumour marker elevation is also known to occur in other confounding situations like smoking, ethanol consumption, COPD, etc., especially if there has been a recent change in habits.

Usually multiple tumour markers are associated with individual malignancy; vice versa, individual tumour markers may be associated with various malignancies. Thus the use of multiple markers based on the combination pattern for the selected malignancy will improve sensitivity and specificity of the detection.

Conclusion

The use of tumour markers in clinical oncology has increased tremendously with rapid expansion of techniques of detection and identification of new markers in recent times, a trend that continues to

grow as technology progresses and our understanding about our body and the disease processes increases. However, such use is not without its pitfalls; in fact, injudicious application of tumour markers is fraught with risks of mistreatment (under-treatment or over-treatment) and its consequences. Of the numerous tumour markers identified, described and extensively researched upon, only a handful of them are used in routine clinical practice; and even of these, only a few have established consensus guidelines for use in day-to-day care of patients.

Judicious application of tumour markers to clinical practice needs a thorough understanding of the basics of pathophysiology, the techniques of identification or testing, reasons (in cases of both benign and malignant tumours) for out-of-range levels of tumour markers, as well as the knowledge of evidence of their role in any given malignancy.

Role of Chemical Pathology in Screening and Diagnosis of Multiple Myeloma

Dr Noreen Sherazi
Chemical Pathology

Multiple myeloma (MM) is characterized by the neoplastic proliferation of a single clone of plasma cells producing a monoclonal immunoglobulin. Normally, plasma cells produce antibodies and play a key role in the immune function. However, uncontrolled growth of these cells leads to bone pain and fractures, anemia, infections, and other complications. In the United States, about four people per 100,000 are diagnosed with MM each year. The average age at diagnosis is 65 to 70 years. The annual incidence of myeloma in the UK is approximately 60-70 per million. Myeloma has a higher incidence in Afro-Caribbean ethnic groups than in Caucasians but there are few other distinctive epidemiological features.

Criteria for Diagnosis — the Diagnosis of Symptomatic MM requires the Following:

- M protein in the blood or urine, plus
- A bone marrow aspirate or biopsy showing that at least 10 per cent of the cells are plasma cells or the presence of a plasma cell tumour (called a plasmacytoma), plus

- Evidence of damage to the body as a result of the plasma cell growth, such as high calcium in the blood, renal failure, anemia or destructive bone lesions (CRAB)

Investigation of a patient with suspected myeloma should include the screening tests indicated followed by further tests to confirm the diagnosis. We at Clinical Chemistry department performing various biomarkers for the screening and diagnosis of multiple myeloma.

Screening Tests

Serum and urine protein electrophoresis

Among the laboratory methods available for the separation of proteins, electrophoresis is a well-established and versatile technique widely used in clinical chemistry. Protein electrophoresis of serum and urine is a sensitive means of detecting the abnormal monoclonal proteins found in myeloma. The test can identify intact immunoglobulin or free light chains in about 98 per cent of the cases.

During electrophoresis of serum proteins, intact monoclonal immunoglobulin molecules will migrate as a sharply defined band. (Figure 1) This is called a

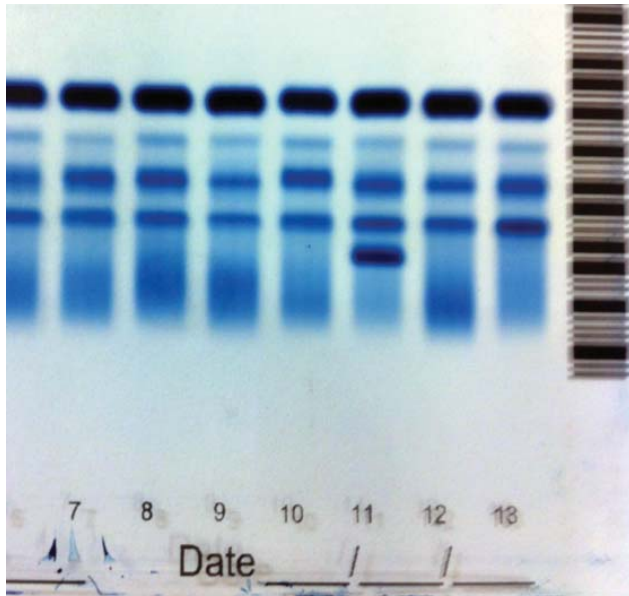

Figure 1: Monoclonal Gammopathy on Serum Protein Electrophoresis (AKUH Lab)

paraprotein, and is detected in about 80 per cent of patients with myeloma. It is almost always found in association with Bence-Jones protein in the urine. Bence-Jones protein is a homogeneous kappa or lambda free light chain.

In most of the remaining 20 per cent of cases of myeloma where a paraprotein is not detected in the serum electrophoretogram, monoclonal light chains are readily detected by protein electrophoresis of concentrated urine. This form of myeloma is usually referred to as Bence-Jones myeloma.

Quantification of Non-Isotypic Immunoglobulins

Measuring total concentrations of IgG, IgA and IgM in serum can reveal elevation of a specific immunoglobulin isotype that is suggestive of the presence of a paraprotein. However, the test does not distinguish between the normal polyclonal and abnormal monoclonal forms of a particular immunoglobulin. This test is therefore not a substitute for the serum electrophoretogram for identifying the presence of a paraprotein in screening for myeloma.

Serum Urea, Creatinine, Calcium & Albumin

Many patients with myeloma have myeloma-related organ impairment (ROTI) in which corrected serum

calcium of usually >0.25mmol/l above the upper limit of normal or >2.75mmol/l and serum creatinine of 1.9 mg/dl is suggestive of ROTI.

Tests to Establish Diagnosis

Immunofixation electrophoresis (IFE) of serum and urine:

Identification of the immunoglobulin isotype of a paraprotein by immunofixation of the paraprotein band enables it to be classified as an immunoglobulin G (IgG), immunoglobulin A (IgA) or immunoglobulin M (IgM) molecule. (Figure 2)

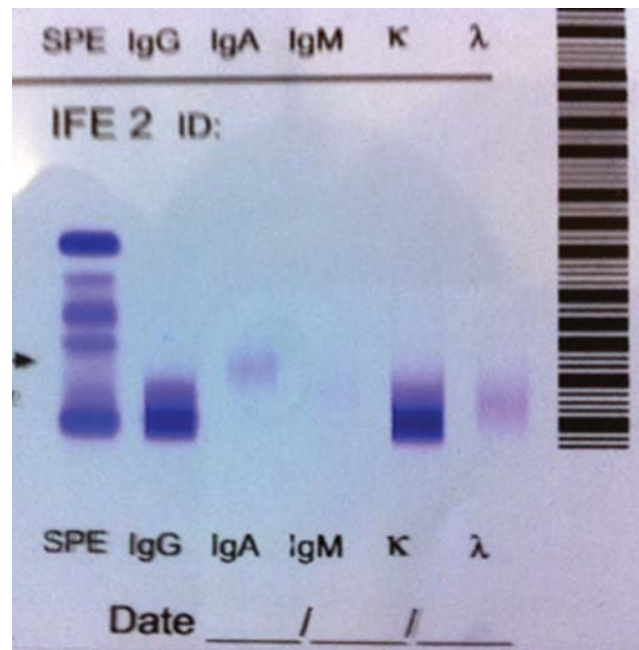

Figure 2: Typing of Immunoglobulins on Immunofixation Electrophoresis (AKUH Lab)

Other isotypes are extremely rare. The identity of the isotype is important in differentiating whether production of the paraprotein is by a clonal plasma cell disorder, or by a clonal lymphoproliferative condition.

IgG and IgA paraproteins suggest a clonal plasma cell disorder. In myelomas which produce paraproteins, IgG paraproteins occur in approximately 75 per cent, and IgA paraproteins in the remaining 25 per cent of cases. An IgM paraprotein is extremely uncommon in myeloma. It is more indicative of a clonal lymphoproliferative disorder, such as low-grade non-Hodgkin’s lymphoma. Waldenstrom’s macroglobulinaemia is an example of one form of low-grade non-Hodgkin’s lymphoma that is characteristically associated with a serum IgM paraprotein.

Tests to Estimate Tumour Burden and Prognosis Quantification of Monoclonal Protein in Serum and Urine

The serum paraprotein concentration can be used for differentiating between the conditions. Concentrations below the threshold value are more likely to be monoclonal gammopathy of uncertain significance and those above are more likely to be myeloma. These values are IgG paraprotein disorders 30 g/L and IgA paraprotein disorders 20 g/L.

Patients with Bence-Jones myeloma have very low serum concentrations of the protein. However, they usually excrete more than 1 g of

Bence-Jones protein in a 24-hour collection of urine.

Beta-2 Microglobulin

Beta-2 microglobulin (B2M) is a useful tumour marker for some blood cell cancers, for detecting kidney damage, and for distinguishing between glomerular and tubular disorders of the kidney. As a tumour marker B2M test help to determine the severity and spread (stage) of multiple myeloma and may sometimes be ordered to evaluate the effectiveness of treatment. B2M has been associated with tumour burden, the amount of cancer present, and may be ordered to help evaluate the prognosis of cancers such as leukemia and lymphoma.

1p/19q Deletion: Favourable Prognostic Marker for Oligodendroglioma

Sony Siddiqui
Histopathology/Molecular Cytogenetics

Multiple chromosome abnormalities are reported in solid tumours, but the major challenge has been to separate critical and irrelevant events. Fluorescence in situ hybridization has emerged as an extremely important tool for detection and characterization of nonrandom chromosome aberrations in cancer. FISH results are utilized for a better understanding of the biological behaviour of the tumour, and to assist in determining the correct therapeutic approach.

Oligodendrogliomas is the third most common glial neoplasm. It can grow in different parts of the brain, but most commonly found in the frontal or temporal lobes of the cerebrum. The frontal lobes are responsible for cognitive thought processes (knowing, thinking, learning, and judging). The temporal lobes are responsible for coordination, speech, hearing, memory, and awareness of time.

There are two types of oligodendroglioma: the well-differentiated tumour, which grows relatively slowly and in a defined shape; and the anaplastic oligodendroglioma, which grows much more rapidly and does not have a well-defined shape. Anaplastic oligodendrogliomas are much less common than well-differentiated oligodendrogliomas.

More common than either form of pure oligodendroglioma is the mixed glioma, or oligoastrocytoma. These mixed gliomas are a mixture of oligodendroglioma and astrocytoma.

Role of 1p/19q as a Prognostic Marker

Among the various candidate biomarkers in gliomas, the 1p 19q codeletion in oligodendroglioma probably constitutes the best-characterized and most extensively investigated marker up to date. Loss of chromosome 1p and 19q is commonly seen in Oligodendroglioma but is rare in other tumour types, such as astrocytomas. The 1p/19q deletion test is useful in tumours with a complex "hybrid" morphology requiring differentiation from pure astrocytomas to support the presence of oligodendroglial differentiation/lineage.

FISH Assay

Specimens from biopsies, excisions or resections of tumours received for FISH assay are handled as soon as possible to preserve tissue morphology. Specimens should be preserved in 10 per cent neutral-buffered formalin (NBF), preferably as 3-4 mm blocks

fixed for 18-24 hours followed by dehydration and embedment in paraffin, for evaluation of 1p and 19q deletions, tumour areas need to be pre-selected under the light microscope. Adequate areas should contain more than 60 per cent of tumour cell infiltration, and no necrosis or hemorrhage. FISH analysis is performed using a dual-color approach for chromosomes 1 and 19 separately. Target probes hybridize to subtelomeric 1p36 and 19q13.3 in combination with control probes on 1q and 19p, respectively.

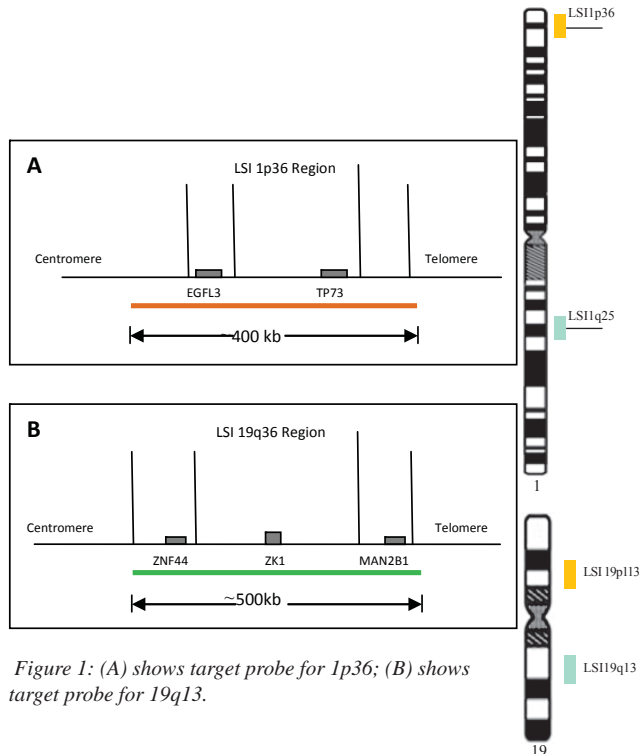

Figure 1: (A) shows target probe for 1p36; (B) shows target probe for 19q13.

The assay is designed with one FISH probe for the long arm of the chromosome (q) and a second probe for the short arm (p).

Interpretation

A normal, undeleted case will show two orange and two green signals per cell while a deletion will have only one orange signal and two green signals.

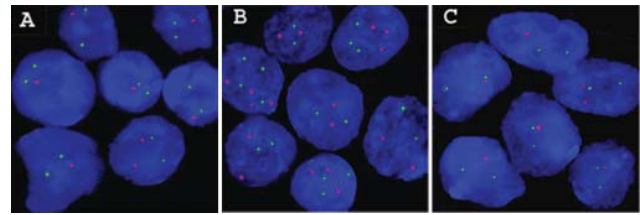

Figure 2: FISH images show tissue sections, hybridized to 1p19q deletion probe. In images A and C orange signal is lost indicating deletion of 1p and 19q respectively; Image B shows two orange and two green signals indicating copies of both the chromosomes. (AKUH Lab)

Detecting 1p and 19q deletions are both diagnostic and predict a favourable response to therapy. Research has shown that anaplastic oligodendroglioma patients who have a loss of heterozygosity on chromosome 1p, or a combined loss of heterozygosity on chromosomes 1p and 19q survive longer (an average of ten years), than patients with tumours that lack these genetic changes (an average of two years).

Therapy

The standard treatment for all grades of oligodendrogliomas is surgery to remove the tumour completely. Oligodendrogliomas are among the only brain tumours that can be successfully treated with a type of chemotherapy called PCV (Procarbazine, CCNU or lomustine, and Vincristine). Chemotherapy is usually used only in cases of recurrent anaplastic oligodendrogliomas. For patients with well-defined oligodendrogliomas, median survival exceeds ten years. For patients with anaplastic dendrogliomas, median survival ranges from two to five years.

EGFR Mutation Screening Test

Toheed Kausar
Molecular Pathology

Non-small cell lung cancer (NSCLC) accounts for about 85 per cent of lung cancers and includes predominantly adenocarcinomas (the most common type) and squamous cell carcinomas.

Table: 1. Frequency of NSCLC in different types of lung cancer

Type of Lung Cancer	Percent of NSCLC
Adenocarcinoma	40-50 per cent
Squamous	30-35 per cent
Large Cell	10-20 per cent

Significant progress has been made during the last 20 years in the molecular characterization of lung tumours. Mutational status in non-small-cell lung cancer is critically important in determining the most effective therapy. EGFR (Epidermal Growth Factor Receptor), KRAS and EML4-ALK (anaplastic lymphoma kinase) are fusion genes; status for these biomarkers in NSCLC is becoming an integral component in treatment decisions.

Traditionally, non-small-cell lung cancers were classified according to their histological features. Various driver mutations have been associated with these cancers over time. The mutations are mutually exclusive, as shown in Figure 1 EGFR mutations are found in 15 per cent of cases from North America, Western Europe, but are reported in 30–50 per cent of patients of East Asian descent with adenocarcinomas with bronchoalveolar features that arise among non-smokers.

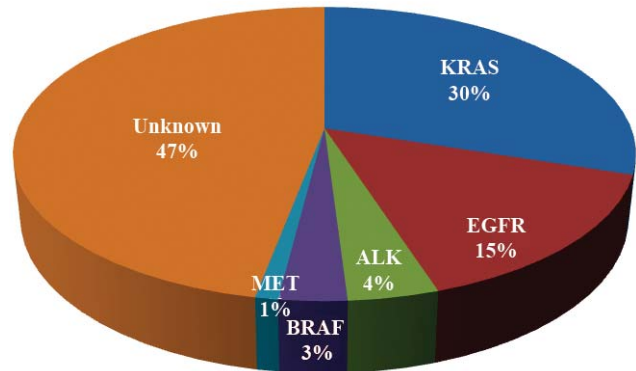

Figure 1: Recurrent Mutations in NSCLC

Overall, KRAS mutations have been reported in 30–50 per cent of patients with adenocarcinoma histology. Whereas the frequency of EML4-ALK translocation ranges from 3 to 7 per cent in unselected NSCLC.

EGFR Basics

EGFR (Epidermal Growth Factor Receptor) is a cell-surface receptor tyrosine kinase, which upon ligand binding leads to activation of various downstream signaling pathways. EGFR is linked to cell growth, proliferation, survival and migration. Clinical studies have shown that a subset of NSCLC patients harbors EGFR mutations (Figure 2), and nearly 85 per cent of those patients benefit from tyrosine kinase

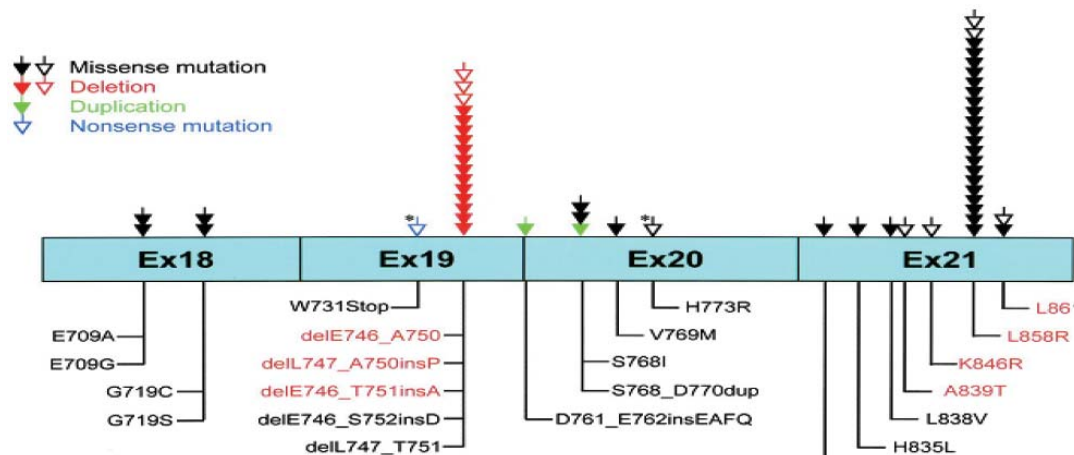

Figure 2: Important EGFR kinase domain mutations (exons 18 to 21)

inhibitors (TKI) therapy. Furthermore, EGFR mutations are found associated with response to gefitinib and erlotinib TKI, and prolonged survival in NSCLC patients.

EGFR Mutation Analysis

The Molecular Pathology Section, The Aga Khan University Hospital Clinical Laboratory, AKUH accepts formalin fixed paraffin embedded tissue (FFPET) blocks for EGFR mutational analysis. Briefly, genomic DNA extracted from FFPET section is PCR amplified using in Real Time PCR chemistry (Figure 3). The assay can detect 41

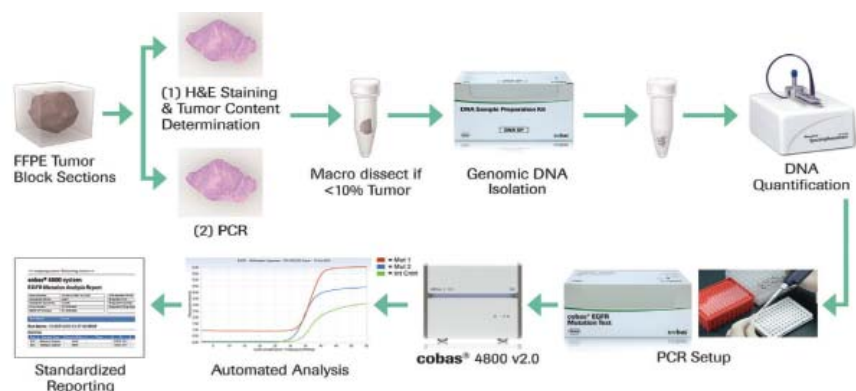

Figure 3: Workflow of EGFR Mutation Analysis Protocol.

different mutations in four exons (18-21) of EGFR gene including several point mutations, deletions and insertions. Currently, EGFR is validated for biopsies of NSCLC.

Significance of EGFR Mutation Analysis

The prevalence of EGFR mutations in unselected cases of NSCLC is approximately 10 per cent. The clinical responses to TKI were shown to be associated with EGFR mutations. However these mutations occur most frequently, but not exclusively,

in non-smoking/ light-smoking female patients of Asian ancestry with adenocarcinoma histologies. Clinical data indicate that patients with advanced NSCLC tumours harboring activating mutations of EGFR, which occur most commonly as deletions in exon 19 or as the L858R point mutation in exon 21, exhibit a high response rate and prolonged progression-free survival (PFS) when treated with anti-EGFR TKIs, both in first- and second-line therapy. Other less common EGFR mutations, such as G719X substitutions in exon 18 and the L861Q point mutation in exon 21 also predict for responsiveness to anti-EGFR therapies. Median survival in patients with EGFR-mutant NSCLC treated with anti-EGFR TKIs is now approximately two years.

But some patients would eventually develop resistance to these TKIs. Subsequent studies found that a secondary mutation in the EGFR gene (T790M mutation) could be the main resistance mechanisms involved. T790M mutation, which is thought to cause steric hindrance and impair the binding of gefitinib/erlotinib. The T790M is present as a minor allele before TKI therapy and accounts for about half of the acquired resistant cases.

The future of molecular testing and adoption of personalized treatments in NSCLC would depend upon identification of new biomarkers and their potential inhibitors. In addition, implementation of routine testing of known biomarkers associated with specific treatments (EGFR, ALK) and our understanding for causes of tumour resistance would create resource for novel therapeutic strategies.

Clinical Utility of BCR-ABL1 Kinase Domain Mutational Analysis

Nazneen Islam
Molecular Pathology

Introduction

Chronic myeloid leukemia (CML) is a chronic hematopoietic stem cell disorder characterized by extensive proliferation and expansion of myeloid cells at varying stages of maturation and differentiation. The Philadelphia (Ph) chromosome (Figure 1) is a hall mark of CML and results from

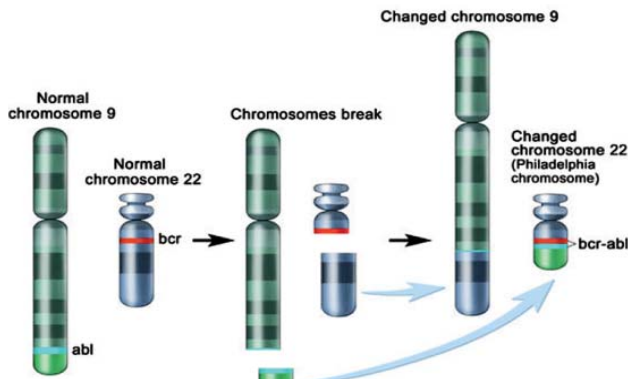

Figure 1: Chromosomal Translocations $t(9; 22)(q34; q11.2)$

the reciprocal translocation between nine and twenty two, creating a fusion gene consisting of break point cluster region and Abelson proto-oncogene (BCR-ABL) with constitutive tyrosine kinase activity resulting in myeloid proliferation.

Imatinib mesylate (Glivec) is currently the standard of care for CML. Glivec is a tyrosine kinase inhibitor (TKI) which induces durable responses in the majority of CML patients. The overall survival of CML patients with complete cytogenetic response is reaching up to 85 per cent at end of seven year’s follow-up period.

Mechanism of Imatinib Resistance

Lately, imatinib resistance has become a significant problem in the management of CML patients. Mutations in the BCR-ABL1 Kinase Domain gene are the most commonly reported mechanism of acquired resistance to imatinib leading to shortened survivals of CML patients.

The frequency of mutation is found to be much higher in the acute phase/blast crisis phase as compare to chronic phase.

Imatinib resistance due to BCR-ABL1 Kinase Domain mutations may arise through a variety of mechanisms. The most common cause of resistance is a conformational change in protein which results from mutation in Kinase Domain drug binding site specifically P-loop or ATP binding region.

Types of BCR-ABL1 Kinase Domain Mutations

To date about ninety different mutations (Table 2) in Kinase Domain which are associated with

Graph 1. Frequency of different BCR-ABL kinase Domain Mutation

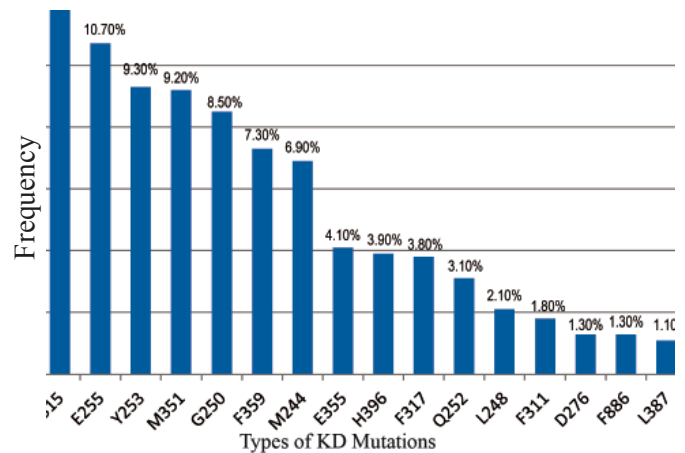

resistance to TKI have been identified. Mostly mutations are clustered within nine amino acid positions on KD genes including T315I, Y253H/F, M351T, G250E, E255K/V, F359V, and H396R. Some of these mutations are found to result in resistance to Imatinib and also second line TKIs such as Dasatinib and Nilotinib. For example, the T315I mutation is the most common KD mutation associated with resistant to all generation of TKI therefore screening for T315I mutation is recommended for all CML patient undergoing treatment.

Molecular uL/uu/LL Based Diagnosis for BCR-ABL Kinase Domain Mutations

The Molecular Pathology section, Clinical Laboratories, AKUH offer DNA sequencing for the detection of BCR-ABL Kinase domain mutations (Figure 3). In this method RNA is extracted and

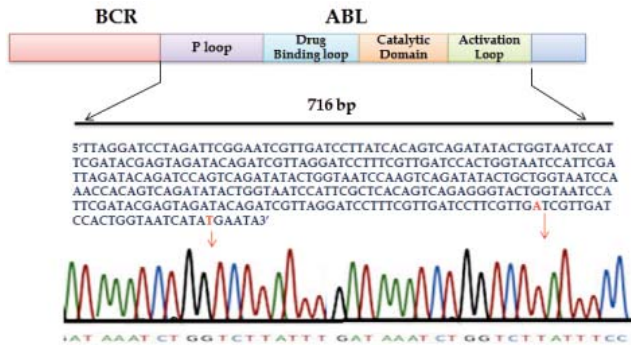

Figure 3: Detection of BCR-ABL kinase domain mutations by direct DNA sequencing.

converted to complementary DNA using a reverse transcriptase enzyme. Complementary DNA is

subjected to PCR amplification using primers that amplify 716 bp regions of KD gene resulting in the formation of a specific PCR product. The PCR product is sequenced using an automated capillary electrophoresis DNA sequencer and the resulting nucleotide sequence is analyzed for the presence of mutations using the Mutation Surveyor software (SoftGenetics, USA).

When to Look for BCR-ABL1 Kinase Domain Mutations

Summary of cases in which BCR-ABL kinase Domain mutation analysis is recommended

At Diagnosis

Only in acute phase/blast crisis phase
During First Line Imatinib Therapy

In case of failure

In case of major molecular response loss

In case of suboptimal response

During second Line Dasatinib or Nilotinib Therapy

In case of hematologic and cytogenetic failure

Utility of Wilms' Tumour Expression in Minimal Residual Disease

Dr Zeeshan Ansar Ahmed and Samina Ghani
 Molecular Pathology

In acute myeloid leukemia (AML), various approaches have been used to characterise minimal residual disease (MRD) such as, immunophenotyping, cytogenetic and molecular analysis. Unfortunately, the methods with higher sensitivity (i.e. molecular based tests) may be hampered by the lack of a specific target marker. A majority of AML cases, do not have a specific cytogenetic and/or molecular alteration that can be used as a reliable or appropriate marker of MRD after morphological remission. The Wilms' tumour gene (WT1) was first cloned in 1990. During embryogenesis the WT1 gene encodes a protein which plays a critical role in normal development of the kidney, gonads, spleen and heart. It also identified as an onco-suppressor gene which encodes a transcription factor that plays a fundamental role in the development of Wilms' tumour. Moreover, it is now evident that WT1 gene values correlate with disease status,

thus being a good candidate for the evaluation of MRD, especially in the relevant percentage of patients who lack a specific molecular marker of their disease.

The WT1 gene is present on chromosome 11p13q and consists of 10 exons. It encodes a transcription factor that required for normal cellular development and cell survival. This gene is highly expressed in several hematopoietic malignancies for example acute myeloid leukemia, acute lymphoblastic leukemia, chronic myeloid leukemia in blast crisis, myelodysplastic syndrome and lymphomas. It also over expressed in various other types of solid tumours likes melanoma, lung, breast, testicular and ovarian cancers.

In the majority of adult patients with leukemia it is possible to achieve a complete remission (CR). In the case of AML, 60-80 per cent of patients reach CR

however; the majority of these patients subsequently relapse. Currently, there is an effort to predict relapse by MRD and subsequently to begin the treatment during clinical and hematological remission prior to overt hematological relapse. Treatment of MRD has a greater probability of success, is less distressing for the patients and also has a lower cost than the treatment of a probable hematological relapse. Consequently, the WT1 gene is a suitable candidate as a marker for monitoring MRD in AML, either in bone marrow or in PB, particularly in patients without specific molecular markers.

The molecular techniques, based on an analysis of nucleic acids, appear to be most useful for MRD monitoring. Molecular techniques are highly specific and in connection with polymerase chain reaction (PCR) also very sensitive. These techniques enable the detection of a proliferation of the leukemic clone weeks or several months prior to the hematological relapse, when the patient is still in hematological and clinical remission. The appropriate marker for MRD monitoring should be over expressed minimally two logs higher in diagnostic samples compared to those from normal healthy individuals. Therefore, estimation of the level of the WT1 expression could be beneficial for predicting hematological relapse. As the WT1 gene is often expressed in patients in permanent remission, it was necessary to establish an upper remission limit which, when exceeded, signals a high risk of hematological relapse. In fact, the upper remission limit defines the molecular relapse level.

However, a persistently elevated WT1 level following therapy is predictive of poor outcome. In addition, it has been demonstrated that normal

hematopoietic recovery following chemotherapy does not significantly modulate WT1 expression levels. Monitoring of disease status with WT1 affords the opportunity to include more AML patients in a single assay than any other leukemic marker and has a potential role in MRD monitoring of patients that are cytogenetically normal.

Method for detection of WT1 expression

For WT1 analysis, RNA is extracted from peripheral blood or bone marrow of diagnosed cases of AML and complementary DNA is synthesized. This cDNA is used for PCR using specific primers to the WT1 gene along with standards and controls to determine WT1 expression.

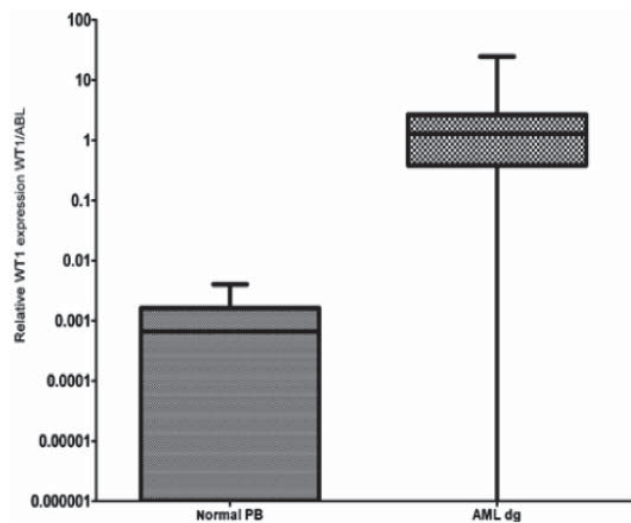

Figure 1. Differential WT1 expression in AML cases as compared with healthy controls. Relative expression of the WT1 gene in peripheral blood of normal healthy donors and AML patients at diagnosis. The bars represent medians and the boxes represent 25th to 75th percentiles of WT1 expression.

Cytogenetic Testing for Acute Myeloid Leukaemia

Marium Ghani
Histopathology/Molecular Cytogenetics

Acute myeloid leukaemia (AML) is a type of cancer that affects immature blood cells on the myeloid cell line leading to neutropenia, anemia, and thrombocytopenia. Differentiation and treatment of acute leukaemias require specialist techniques including cytochemical staining, immunophenotyping and chromosome studies (cytogenetics).

Laboratory Tests used to Diagnose Acute Myeloid Leukaemia

One or more of the following lab tests may be done on the samples to diagnose AML and/or to determine the specific subtype of AML.

Morphology: Blood and marrow smears are morphologically examined using a May-May-Grünwald-Giemsa or a Wright-Giemsa stain.

Immunphenotyping: Multiparameter (commonly at least three to four color) flow cytometry is used to determine lineage involvement of a newly diagnosed acute leukemia.

Conventional cytogenetics: Conventional cytogenetics analysis is a mandatory component in the diagnostic evaluation of a patient with suspected acute leukemia. A minimum of 20 metaphase cells are analyzed from bone marrow/ blood which is considered mandatory to establish the diagnosis of a normal karyotype, and recommended to define an abnormal karyotype.

Molecular cytogenetics: Methanol/acetic acid-fixed cell pellets should be stored so if cytogenetic analysis fails, fluorescence in situ hybridization (FISH) is an option to detect gene rearrangements, such as RUNX1-RUNX1T1, CBFβ-MYH11, MLL and EVI1 gene fusions, or loss of chromosome 5q and 7q material. FISH analysis has several advantages over chromosome studies. It has a rapid turnaround time, detects small numbers of abnormal cells, and can also be performed on non-dividing (interphase) cells. It can detect cryptic or subtle rearrangements that might be difficult to detect by routine karyotyping. In addition, FISH is frequently necessary to identify MLL fusion partners in 11q23 translocations.

Molecular genetics: Molecular diagnosis by reverse transcriptase-polymerase chain reaction (RT-PCR) for the recurring gene fusions, such as RUNX1-RUNX1T1, CBFβ-MYH11, MLLT3-MLL, DEK-NUP214, and somatically acquired mutations in several genes, for example, the NPM1 gene, the FLT3 gene, the CEBPA gene, myeloid/lymphoid or mixed-lineage leukemia (MLL) gene, the neuroblastoma RAS viral (v-ras) oncogene homolog (NRAS) gene, the Wilms tumour 1 (WT1) gene, the v-kit Hardy-Zuckerman 4 feline sarcoma viral oncogene homolog (KIT) gene, runt-related transcription factor 1 (RUNX1) gene, the tet oncogene family member 2 (TET2) gene, and the isocitrate dehydrogenase 1 (NADP+),

soluble (IDH1) gene can be useful in certain circumstances.

Genome-wide studies: Recent progress in genomics technology has resulted in the identification of novel genetic abnormalities and holds the promise of making the systematic characterization of cancer genomes feasible. It includes gene- and microRNA-expression profiling and single nucleotide polymorphism (SNP)-based mapping arrays.

Prognostic Information for Patients with Acute Myeloid Leukaemia

The outcome for patients with AML depends on a variety of factors including age of the patient, intensity of postremission therapy, biologic characteristics of the disease and the most important of which are the cytogenetics at presentation. Results of cytogenetic analysis at diagnosis provide important prognostic information in AML and aids in monitoring response to therapy or progression of the disease. Following are the cytogenetics risk groups which can be found in patients with AML:

Risk Group	Abnormality	Comment
Favorable	t(8;21) t(15;17) inv(16)	Whether alone or in conjunction with other abnormalities.
Intermediate	Normal +8 +21 +22 del(7q) del(9q) Abnormal 11q23 All other structural/numerical abnormalities	ie, Cytogenetic abnormalities not classified as favorable or adverse. Lack of additional favorable or adverse cytogenetic changes.
Adverse	-5 -7 del(5q) Abnormal 3qComplex	Whether alone or in conjunction with intermediate-risk or other adverse-risk abnormalities.

Ref: Grimwade et al, Blood 1998;92:2322-2333

AML Panel by FISH Offered by the Clinical Laboratory

For FISH testing, a sodium-heparin (green-top) tube with 3–4 ml of blood/ bone marrow is required. Samples should be stored at room temperature and transported to the laboratory within 24 hours of draw. Bone marrow cells on unstimulated cultures either from direct harvest or 24 hour culture are analyzed by FISH using a set of commercially available FISH probes (Vysis, Abbott). Each probe can be run as a part of the panel or individually. Following are the

FISH probes available at the cytogenetics laboratory of the AKUH and can be requested for AML:

t(8;21): AML with t(8;21)(q22;q22) is seen most often in patients with M2 and is defined by the presence of this translocation, a variant translocation, or molecular RUNX1-RUNX1T1 fusion.

t(15;17): AML with t(15;17)(q22;q21)/PML-RARA is a distinct clinicopathologic entity defined by the presence of the PML-RARA fusion and is seen most often in patients with M3 (Figure 1 and Figure 2).

t(11q23:var): AML with t(9;11) is seen in patients with M0-M7 subtypes and is the only translocation involving the MLL gene included as a distinct biologic subtype. Although >60 fusion partner genes are known for MLL, the more common translocations in AML include 6q27 (MLLT4), 10p12 (MLLT10), 19p13.1 (ELL), and 19p13.3 (MLLT1), all resulting in fusion genes.

inv(16): AML with inv(16)/t(16;16) is seen most often in patients with M4 and is defined by the translocation and/or molecular fusion of CBFβ and MYH11.

+8: Trisomy eight in AML occurs in patients with M0-M7 subtypes either as the sole anomaly or together with other clonal chromosome aberrations.

-7/7q deletion: is frequent in secondary MDS or AML, and also in leukemias occurring in individuals with constitutional syndromes including predisposition to myeloid disorders.

-5/5q deletion: Deletion of 5q can be observed in

both de novo and therapy related AML. It is also seen as monosomy five. In AML, 5q deletion is usually associated with a complex karyotype. The most commonly observed interstitial deletions are del(5)(q13q31), del(5)(q13q33), and del(5)(q22q33), forming a commonly deleted region (CDR) at 5q31-q32.



Figure 1: G-banded karyotype with t(15;17)(q22;q21) at arrows (Wakim et al. 2012).

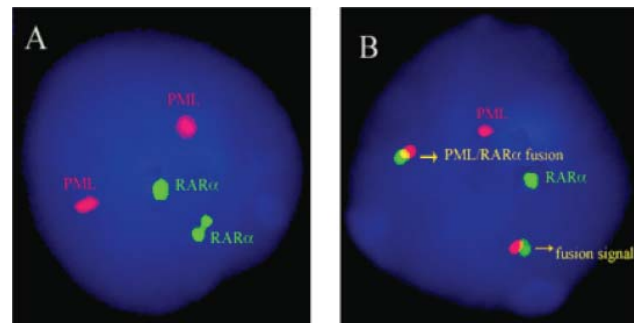

Figure 2: Dual-color Dual-fusion translocation probe for the detection of PML-RARA fusion. Panel A shows a normal FISH pattern (2R, 2G), whereas panel B reveals fusion of the PML and RARA loci at arrows. (Clinical Laboratory)

Diffuse Large B-Cell Lymphoma Subgroups have Different Phenotype

Dr Shahid Pervez & Dr Arsalan Ahmed
Histopathology,

Diffuse large B-cell lymphoma is the most common lymphoma subtype, accounting for 30 per cent of all non-Hodgkin's lymphomas (NHL). It shows an aggressive clinical course, and comprises a heterogeneous group of lymphomas in terms of morphology, immunophenotype and molecular abnormalities.

DLBCL, NOS includes three common morphologic variants (centroblastic, immunoblastic and anaplastic) plus rare morphologic variants. These variants are important for pathologist to recognize so they are not misdiagnosed as either indolent or lymphoblastic lymphomas.

DLBCL can also be divided based on cell of origin. The WHO lists two molecular and IHC subgroups: Germinal center-like (GCB) and non-germinal center-like (non-GCB) subgroups. Gene-expression profiling studies have distinguished three molecular subtypes of DLBCL known as “germinal center B-cell-like” (GCB), “activated B-cell-like” (ABC), and “primary mediastinal B-cell lymphoma” (PMBL). GCB DLBCLs seem to arise from normal germinal center B cells, ABC DLBCLs may arise from

postgerminal center B cells that are arrested during plasmacytic differentiation, and PMBLs may arise from thymic B cells.

Since gene expression profiling (GEP) has remained as an impractical clinical tool, a number of immunohistochemical algorithms have been proposed to translate GEP classification into a manageable set of measurable proteins to distinguish between GCB and non-GCB type DLBCL. (Figure 1)

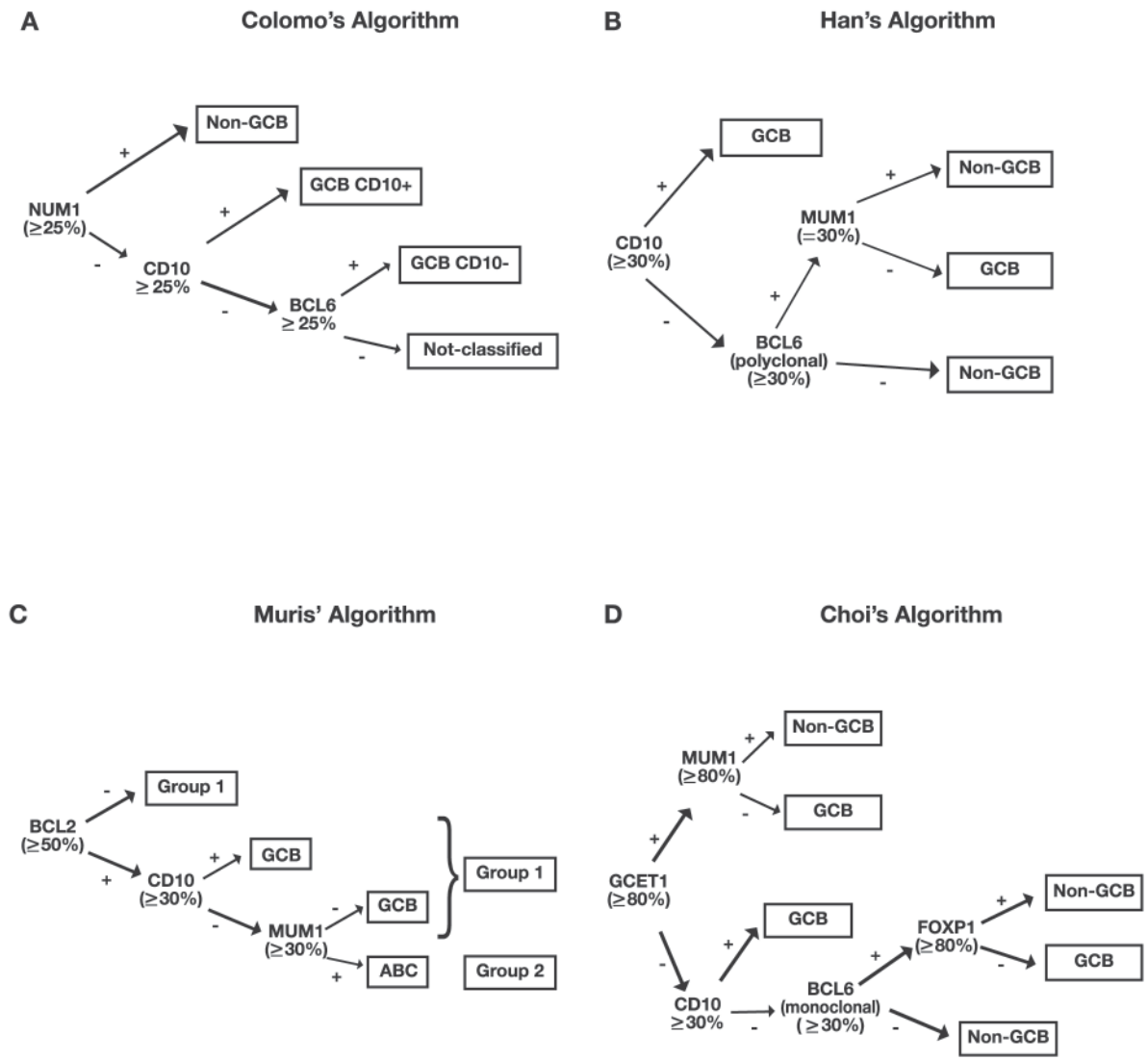

Figure 1: Four immunostaining algorithms used to assess differentiation profile (GCB vs non-GCB) in patients with DLBCL.

The best known is ‘‘Hans algorithm’’. According to this algorithm, GC group is CD10+ and/or BCL6+, MUM-1-. The non-GCB group is CD10-, BCL6+, MUM1+ or CD10-, BCL6-. There are some unresolved issues attached to this algorithm. First, not everyone interprets the GC group in the same way. According to some, both CD10 and BCL6 should be positive, while some believe either is fine, but MUM1 and CD138 should be negative. Secondly not everybody will find that GCB group does better than non-GCB group. (Figure 2)

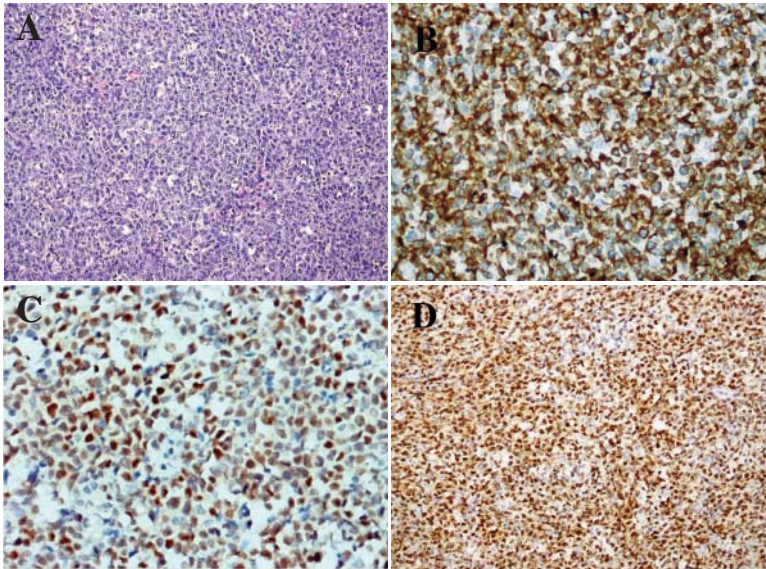

Figure 2: (A): Diffuse Large B-cell Lymphoma (DLBCL) (H&E), (B) DLBCL stained with anti-CD10 antibody with strong diffuse cytoplasmic staining consistent with ‘Germinal Centre (GC) phenotype’, (C) DLBCL stained with anti-Bcl6 antibody showing strong nuclear staining consistent with GC phenotype, (D) DLBCL stained with anti-MUM1 antibody showing strong diffuse nuclear staining consistent with ‘Post-Germinal Centre phenotype’. (Courtesy: AKUH Lab)

This algorithm, however, was designed for use in patients treated with CHOP without rituximab (pre-rituximab era), and in addition, it had low concordance with GEP analysis (71 per cent for

GCB, 88 per cent for non-GCB). The prognostic relevance of the Hans algorithm led to inconsistent results in subsequent studies performed in patient groups treated with R-CHOP. Nevertheless, the Lymphoma/Leukemia Molecular Profiling Project (L/LMPP) has demonstrated the GCB group still does better than the non-GCB group in the ‘‘R-CHOP’’ era. The literature remains inconsistent and indecisive. Some studies have shown that the GCB group did better than the non-GCB group when CHOP therapy was used but no differences could be seen with R-CHOP, while some have reported that GCB did no better than non-GC group after treatment with R-CHOP. Others have reported no differences even in the CHOP era. There is a newer algorithm (Choi and coworkers) that compared to the their Hans algorithm improves concordance with the gene expression profiling data from 86 per cent to 93 per cent using GCET1 and FOXP1 antibodies in addition to CD10, BCL6 and MUM1.

Newer algorithms have also been proposed which include Tally algorithm and the latest algorithm was proposed in International DLBCL Rituximab-CHOP Consortium Program Study. This latter algorithm boasts to have a simpler structure than other recently proposed algorithms and is based on the expression of CD10, FOXP1, and BCL6 and has a 92.6 per cent concordance with GEP.

Others who recently tested multiple algorithms suggest that none work and what you really need are gene expression profiling studies, unfortunately an impractical suggestion. In the end we believe that more work has to be done in this field and that one should still be careful in using these algorithms for determining prognosis between GCB and non-GCB DLBCL subgroups.

Meeting Report: 1st Joint Conference of PAP/ Societies of Pathologists and 36th Annual Conference Pakistan Association of Pathologists

Reported by Dr Hafsa Majid
Resident, Chemical Pathology

The 1st Joint Conference of Pakistan Association of Pathologist (PAP) and Societies of Pathologists was held in Islamabad from 7th - 9th Dec 2012. This conference was hosted by Armed Forces Institute of Pathology (AFIP) at the Convention Centre Islamabad. The conference excelled in presenting exciting developments in the field of pathology and laboratory medicine; some of the highlights are reported here. Preconference workshops of Histopathology, Haematology, Microbiology, Chemical Pathology and Immunology were conducted by the hosting institute. The goal was to facilitate participants in exploring new areas in respective fields at an interactive learning forum.

Pathologists, trainees and laboratory personnel from all over Pakistan and abroad attended this conference. The first day began with inauguration ceremony on evening of 7th December followed by the 'Razi lecture', given by Professor Aw Tar Choon, from Singapore on 'Clinical application of circulation tumor cells'. Jabir Ibn Hayyan lecture was given by Dr DP Mikhailidis from United Kingdom, who highlighted on cardiovascular risk assessment and emphasized on utility of risk prediction tools. Evening ended with a banquet dinner and Mehfil-e-Hamd o Naat.

Second day December 8, 2012 started with Ibn-e-Sina lecture given by Prof Dr Lawrence Faulkner

from United Kingdom on role of international NGOs to improve access to cure and prevention of hemoglobinopathies in developing countries, followed by plenary state-of-the-art lectures delivered by eminent pathologists from United Kingdom. Guest speakers talked on range of topics from organ transplant, DNA testing to paper publication, which generated exciting discussions. These lectures were followed by plenary lectures in different disciplines of pathology given by Aga Khan University (AKU) faculty and other pathologists from Pakistan. Parallel scientific sessions of free papers gave participants including a large number of AKU residents great learning opportunity by sharing work on a national platform. Several selected abstracts were also displayed as posters which portrayed research advances in the field of pathology. The scientific sessions were followed by banquet dinner.

The Third day conference was held at Barian, Murree. Day started by meet the experts' sessions, a great learning opportunity for budding pathologists for learning from experts in their respective fields. This was followed by plenary sessions. The conference closing ceremony was in afternoon followed by a marvelous meal and lively social discussion. It was a wonderful way to finish the conference. Like always the conference was successful in bringing together delegates from the different disciplines of pathology and laboratory medicine and allowing opportunity for a healthy debate.

Pathology and Microbiology Research Day 2012

Dr. Hafsa Majid
Resident, Chemical Pathology

The first Pathology and Microbiology Research Day of Aga Khan University Hospital was held on October 11, 2012 at Pearl Continental Hotel, Karachi. This event showcased original research studies from residents and faculty of Department of Pathology and Microbiology.

The programme started with recitation from Holy Quran, welcoming address was given by the department's Chair Dr Naila Kayani followed by an introductory speech given by Chair of research day's organizing committee, Dr M. Asim Baig. Residents, staff and junior faculty from all sections of Pathology and Microbiology shared their research work with their fellow trainees, faculty and other investigators via presentation of free papers and poster session.

Renowned scientist of Pakistan Dr Atta-ur- Rahman was invited as guest speaker, who gave an enlightening talk on developments in the field of research in Pakistan. This was followed by a talk given by Dean, Research and Graduate Studies AKU, Dr El-Nasir Lalani on need of developing research activities to help us achieve the challenges posed by



Pathology Research Day 2012

accelerating scientific changes. Final address was by Dean, Medical College AKU, Dr Farhat Abbas who highlighted that the importance is not only to do research but also to get that research out to the scientific community. He also congratulated the organizers of the event for arranging a platform that provided the opportunity to budding researchers to present their work to a large scientific community. The program ended with certificate distribution and the participants were then provided the opportunity to interact with each other and the guests during dinner.



hospitals.aku.edu/Karachi/pathologymicrobiology